

# **SCHEMI A BLOCCHI**

## **Componenti di uno schema a blocchi**

## **Regole di elaborazione**

## COMPONENTI DI UNO SCHEMA A BLOCCHI

- Rappresentazione di un sistema dinamico

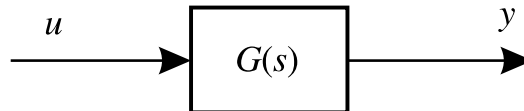

- Nodo sommatore

$$\star y(t) = u_a(t) + u_b(t) - u_c(t)$$

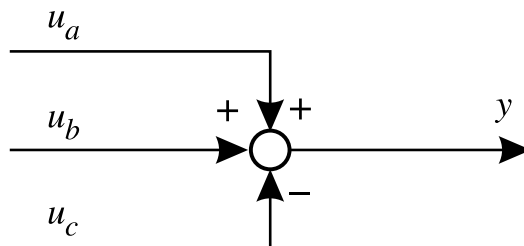

- Punto di diramazione

$$\star y_a(t) = y_b(t) = y_c(t) = u(t)$$

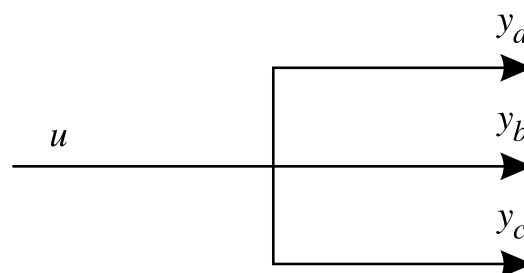

- Esempio

$$u(t) = \begin{bmatrix} u_1(t) \\ u_2(t) \end{bmatrix} \quad y(t) = \begin{bmatrix} y_1(t) \\ y_2(t) \end{bmatrix}$$

$$\star Y(s) = G(s)U(s)$$

$$G(s) = \begin{bmatrix} G_{11}(s) & G_{12}(s) \\ G_{21}(s) & G_{22}(s) \end{bmatrix}$$

$$Y_1(s) = G_{11}(s)U_1(s) + G_{12}(s)U_2(s)$$

$$Y_2(s) = G_{21}(s)U_1(s) + G_{22}(s)U_2(s)$$

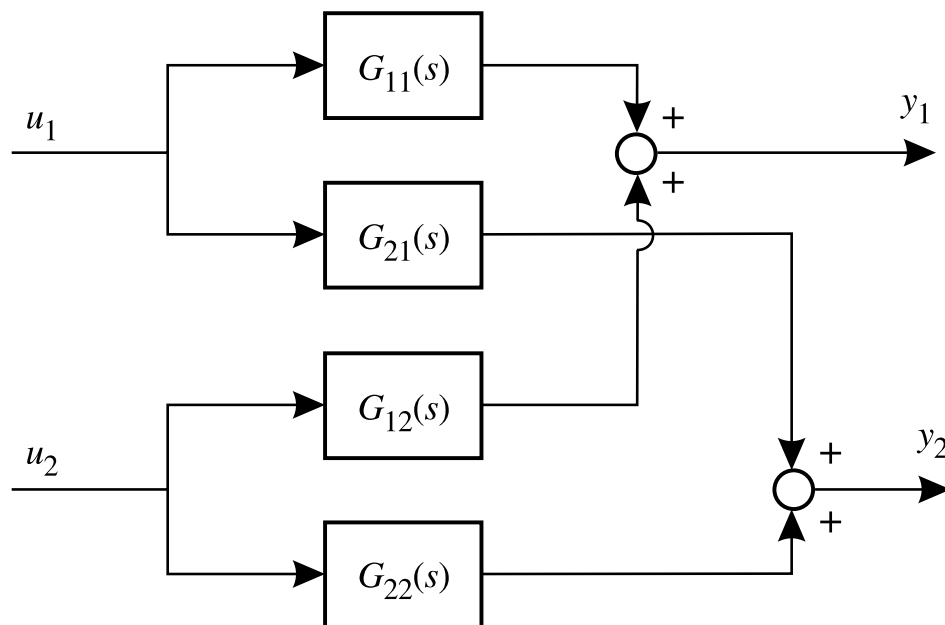

● Esempio: sistema idraulico

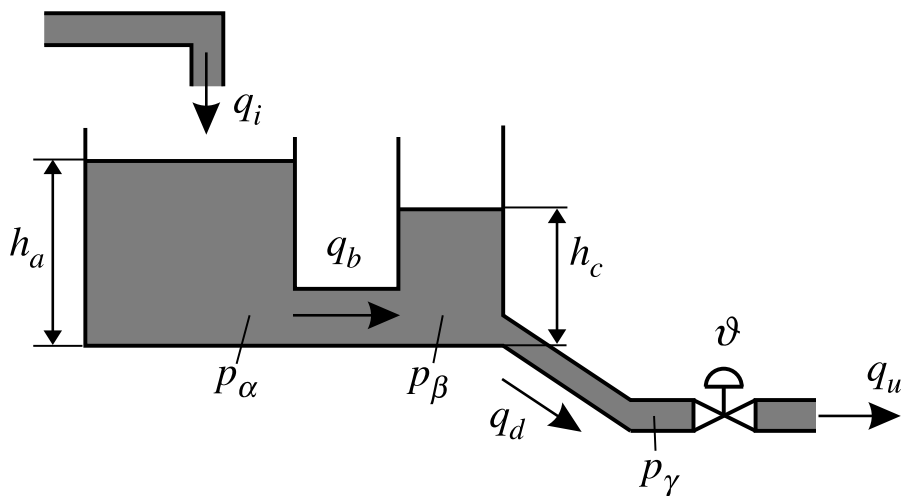

★ schema a blocchi

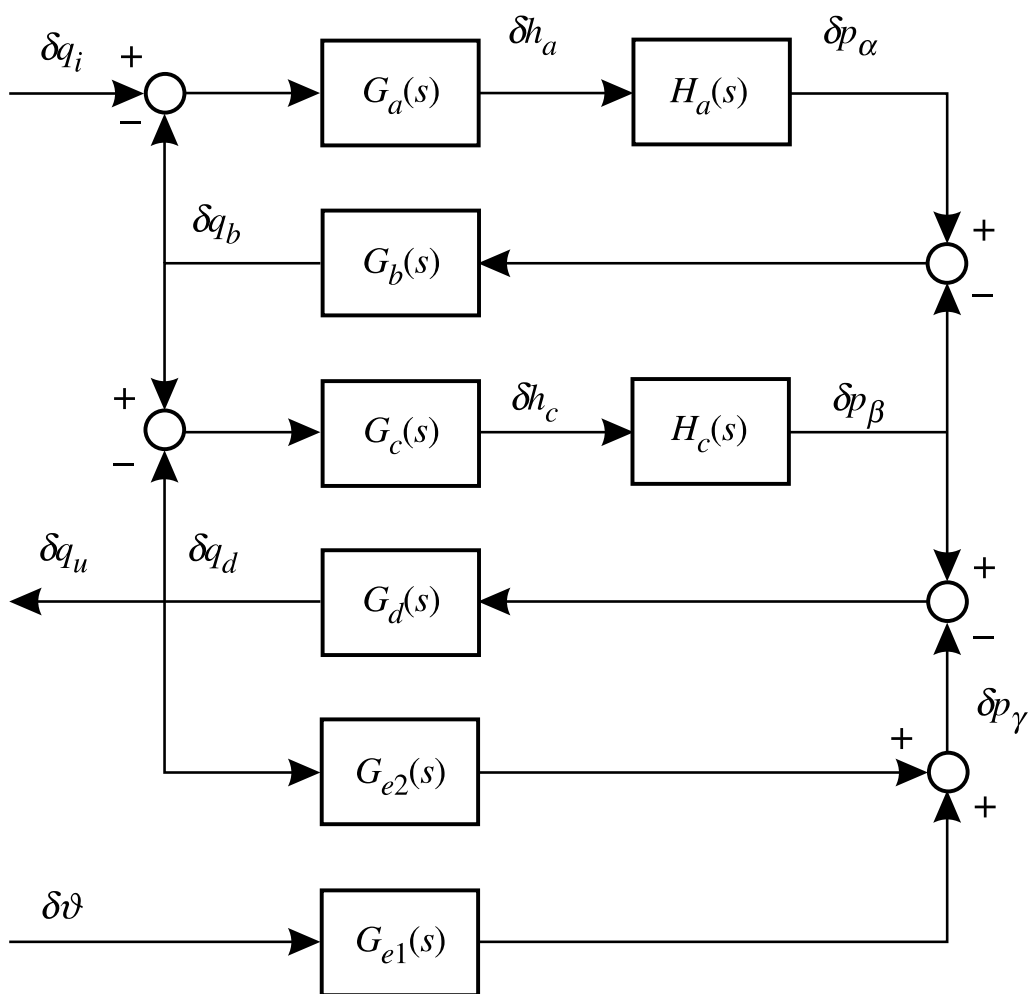

## REGOLE DI ELABORAZIONE

- Connessione di due sistemi

$$Y_a(s) = G_a(s)U_a(s)$$

$$Y_b(s) = G_b(s)U_b(s)$$

### Sistemi in serie (o in cascata)

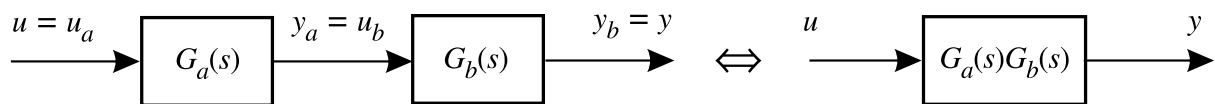

- Sistema complessivo

$$Y(s) = G_b(s)Y_a(s) = G_b(s)G_a(s)U(s)$$

$\Downarrow$

$$G(s) = \frac{Y(s)}{U(s)} = G_a(s)G_b(s)$$

## Sistemi in parallelo

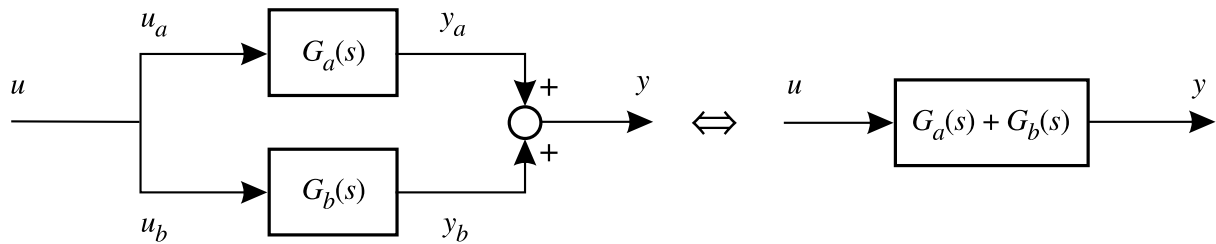

- Sistema complessivo

$$\begin{aligned} Y(s) &= Y_a(s) + Y_b(s) = G_a(s)U_a(s) + G_b(s)U_b(s) \\ &= (G_a(s) + G_b(s))U(s) \end{aligned}$$

⇓

$$G(s) = \frac{Y(s)}{U(s)} = G_a(s) + G_b(s)$$

## Sistemi in retroazione negativa (o controreazione)

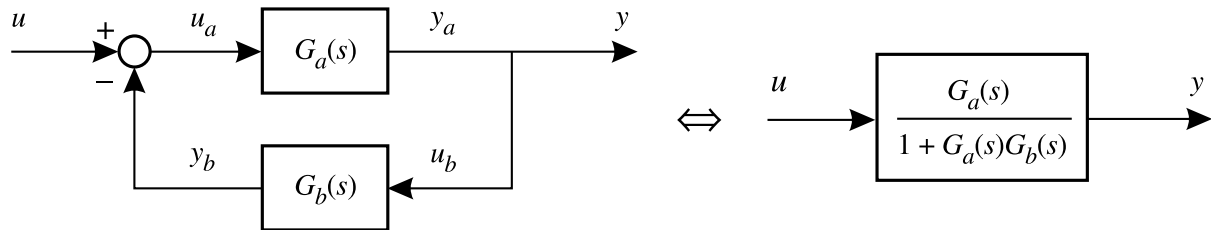

- Sistema complessivo (in anello chiuso o retroazionato)

$$Y(s) = G_a(s) (U(s) - Y_b(s)) = G_a(s) (U(s) - G_b(s)Y(s))$$

$\Downarrow$

$$G(s) = \frac{Y(s)}{U(s)} = \frac{G_a(s)}{1 + G_a(s)G_b(s)}$$

- ★ funzione di trasferimento d'anello

$$L(s) = G_a(s)G_b(s)$$

- ★ anello algebrico

$$\lim_{s \rightarrow \infty} L(s) = -1 \quad \Longrightarrow \quad \lim_{s \rightarrow \infty} G(s) = \infty$$

- Sistemi in retroazione positiva

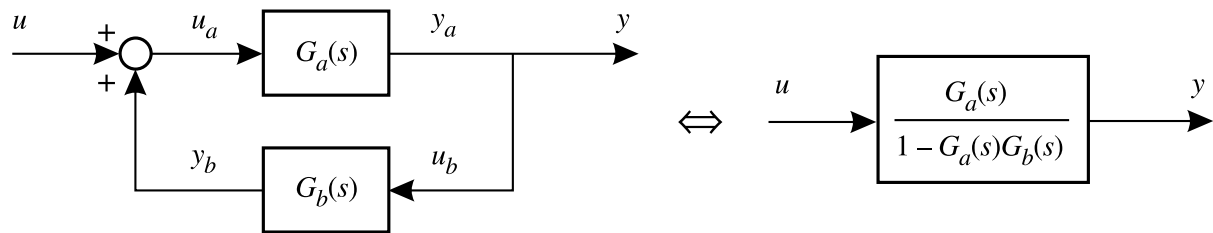

- Sistema complessivo

$$G(s) = \frac{Y(s)}{U(s)} = \frac{G_a(s)}{1 - G_a(s)G_b(s)}$$

★ condizione di congruenza

$$\lim_{s \rightarrow \infty} L(s) \neq 1$$



## Riduzione di schemi a blocchi

- Esempio (precedente)

★ schema equivalente

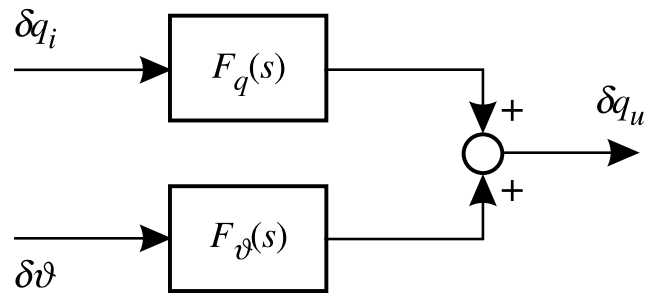

★ successive elaborazioni

$$M_1(s) = \frac{G_d(s)}{1 + G_d(s)G_{e2}(s)}$$

$$\begin{aligned} M_2(s) &= \frac{G_c(s)H_c(s)}{1 + G_c(s)H_c(s)M_1(s)} \\ &= \frac{G_c(s)H_c(s)(1 + G_d(s)G_{e2}(s))}{1 + G_d(s)G_{e2}(s) + G_c(s)H_c(s)G_d(s)} \end{aligned}$$

$$M_3(s) = \frac{G_b(s)}{1 + G_b(s)M_2(s)}$$

$$\begin{aligned} M_4(s) &= M_2(s)M_1(s) \\ &= \frac{G_c(s)H_c(s)G_d(s)}{1 + G_b(s)G_{e2}(s) + G_c(s)H_c(s)G_d(s)} \end{aligned}$$

$$\begin{aligned} M_5(s) &= \frac{G_a(s)H_a(s)M_3(s)}{1 + G_a(s)H_a(s)M_3(s)} \\ &= \frac{G_a(s)H_a(s)G_b(s)}{1 + G_b(s)M_2(s) + G_a(s)H_a(s)G_b(s)} \end{aligned}$$

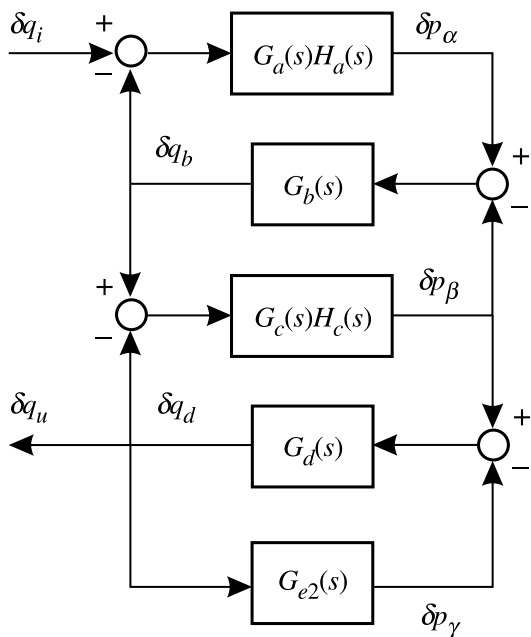

a)

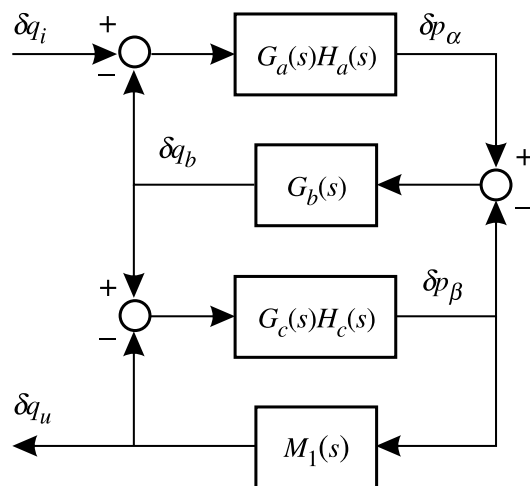

b)

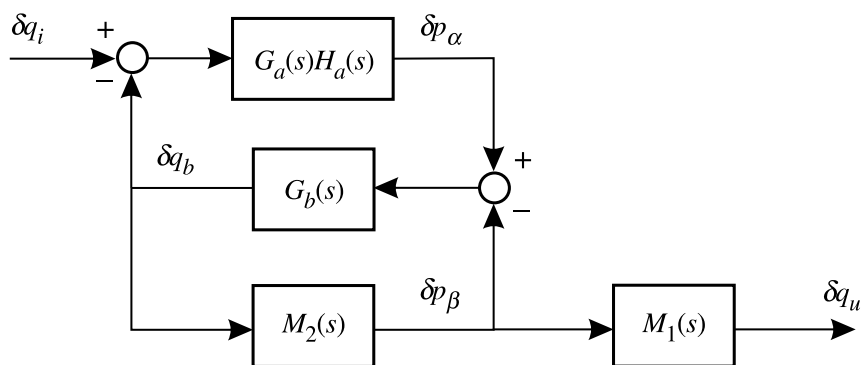

c)

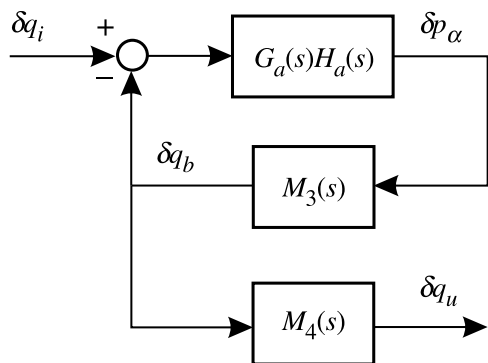

d)

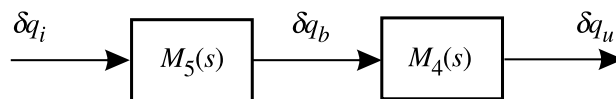

e)

★ in conclusione

$$K(s) = 1 + G_a(s)H_a(s)G_b(s) + G_b(s)G_c(s)H_c(s)$$

$$\begin{aligned} F_q(s) &= M_4(s)M_5(s) \\ &= \frac{G_a H_a G_b G_c H_c G_d}{[1 + G_d G_{e2}]K + [1 + G_a H_a G_b]G_c H_c G_d} \\ F_\vartheta(s) &= \frac{-G_d G_{e1} K}{[1 + G_d G_{e2}]K + [1 + G_a H_a G_b]G_c H_c G_d} \end{aligned}$$

- Due schemi equivalenti

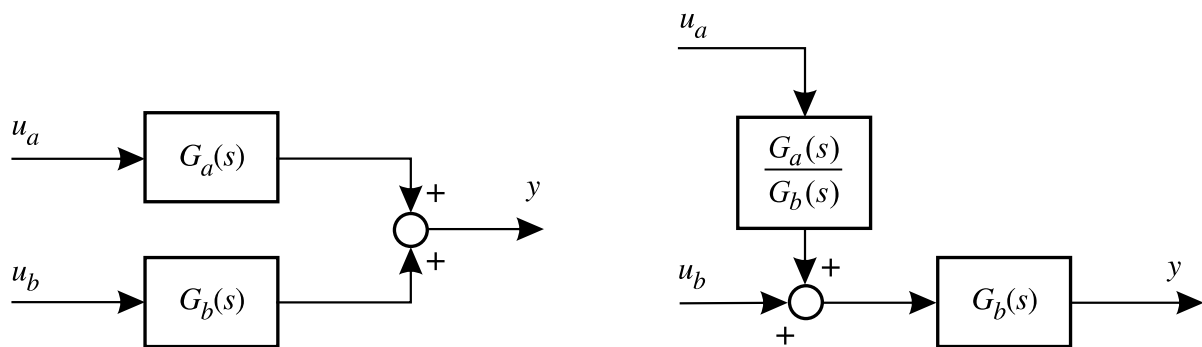

★  $G_a(s)/G_b(s)$

potrebbe avere un polinomio a numeratore di grado maggiore di quello del polinomio a denominatore

potrebbe contenere termini di anticipo qualora  $G_b(s)$  contenga un ritardo